

myMix

the über mixer



- ⇒ Impeccable Audio Quality - uncompressed 24-bit /48kHz
- ⇒ Virtually unlimited Audio Channels and Mixers in the Network
- ⇒ Share the Mix with others on the Network
- ⇒ Built-in Choice of Effects
- ⇒ Simple CAT5 Connection
- ⇒ Ideal for use with In-Ear- Monitors, Headphones or Speakers
- ⇒ Analogue and Digital Inputs
- ⇒ Multitrack Recording and Playback

Networkable Personal Monitor Mixing - and more!

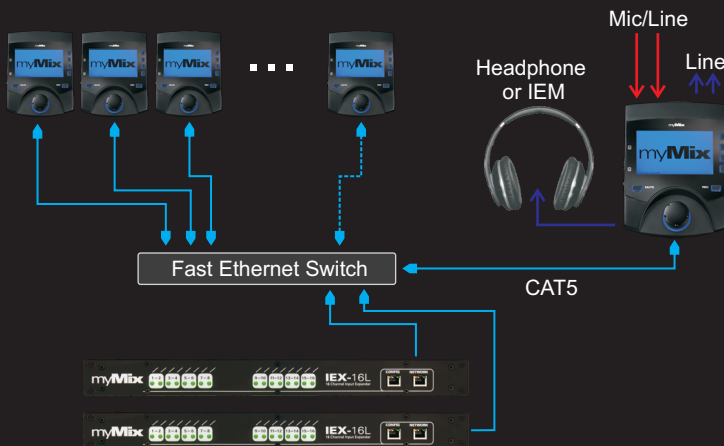

myMix is a networked based all new monitor mixing system with a large number of applications on stages, in studios, in rehearsal rooms, music schools, at home and many more places.

The easy to use, intuitive user interface allows every user to be in control of his/her own monitor mix. The raw channel signals and the mix can be recorded to SD card and also played back and re-mixed.

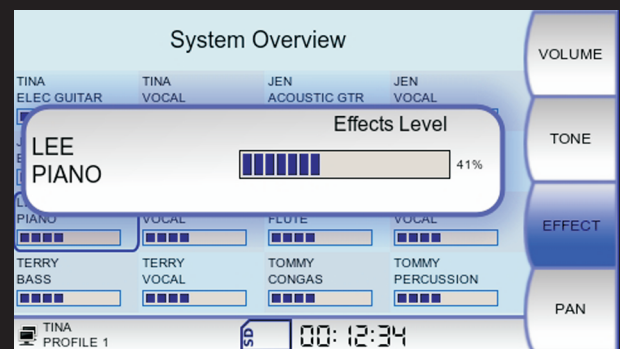

Each myMix unit has two mic/line inputs and the outputs for the stereo mix signal (headphone & balanced line level). They are connected to a conventional Fast Ethernet switch via CAT5 cable.

Each myMix sends its own local input signals and / or its mix to the network, while receiving up to 16 signals from the network. IEX-16L input expanders can be used to feed additional analogue (line level) or digital (ADAT) signals to the system. The myMix network can handle hundreds of audio channels, so everybody can make an individual selection of signals for their own mix.

All channels in a myMix system can be named - mixing is as simple as selecting the instrument or vocal mic, press the button and adjust: volume, tweak the tone, add some effects and pan the signal within the stereo image. All settings, including the 4 band master PEQ are automatically stored in the current profile. 20 profiles are available to simplify operation. myMix lets you enjoy your music more.



myMix - A New Way of Leading Educational Music Programs

Whether listening to multiple students, providing the students the ability to play with a group or band (using the play along function), or simply recording the homework for the teacher to check - myMix opens the way to the future of teaching and learning music. The easy-to-use interface, automatically stored settings and the great audio quality increases the level of performance for students and teachers.

Listen and Talk to Multiple Students

The teacher can listen and talk to multiple students individually while they play.

The students can listen to their instruments and the teacher's comments, and (if enabled) talk to the teacher. They can play on their own, play along with pre-recorded multi-track material from the SD card, or play as a group together with other students.

The profiles capture the configuration as well as the mixes to allow for fast and easy change over between different set-ups.

The teacher also uses profiles to select between the individual students, or listen and talk to the whole group.

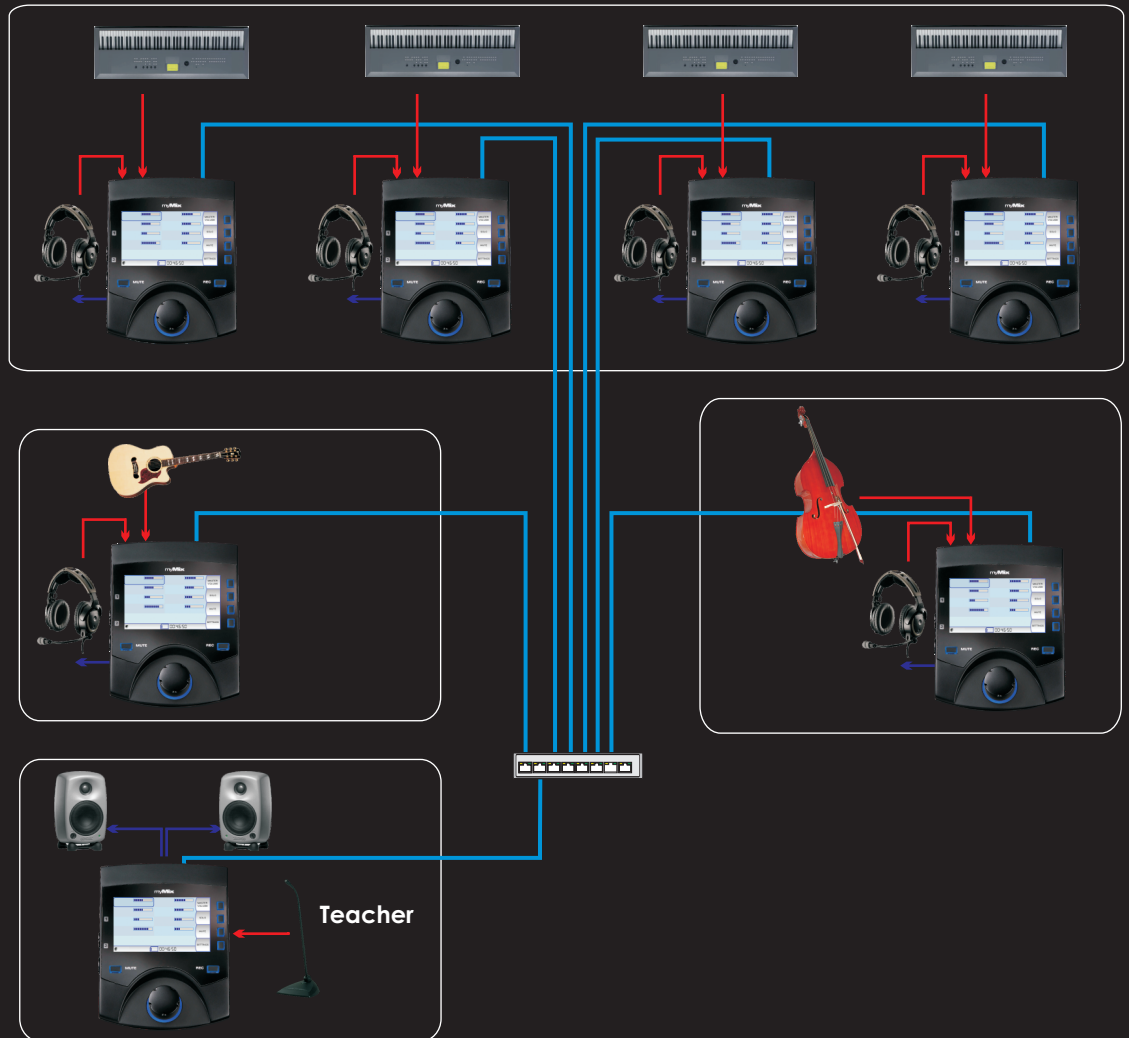

Rehearsing and Recording Using Multi-Track Playback and Play Along

Playing back and re-mixing a multi-track session make myMix the ultimate rehearsal and playback device. Multitrack sessions can either be recorded on myMix or created from existing material using the myMix Wave software tool.

In Play Along mode, the local inputs become available to be mixed with the individual tracks from the SD card. So a whole band, or the string quartet is always around for a jam session or rehearsal - even when you are the only one there. And if you play with others over the myMix network, you can activate „Send Mix to Network“ and allow others to listen to your mix.

Want to know more or schedule a demo?

Call: 952 657 7889

Email: info@movekcorp.com



www.mymixaudio.com