

myMix System White Paper, October 2012

by Christian Glueck, product manager myMix

myMix a Decentralized, Networkable Audio Mixing System for Personal Monitoring and A/V applications

Summary

myMix is a networked personal monitor mixing and recording system that allows each user to create an individual stereo mix. A focus in the development was the user interface with a bright LCD screen, that operates name based, easy to operate also by non audio engineers. In January 2012 it got approved for a US patent (8098851). All devices are networked via standard Fast Ethernet (100MBps) switches. Each myMix has two local inputs for microphone or line signals and a stereo master output. The inputs signals as well as the stereo mix can both be shared with others over the network. Additional inputs can be added with IEX16L input expanders. There is virtually no limitation as of how many audio channels are used in a myMix network. As there is no center or master unit and networking is via conventional Fast Ethernet hardware, the myMix system can be scaled from a single unit up to hundreds of devices. They can be operating stand alone (without a mixing console) or integrated into a larger sound system.

myMix utilizes an "Ethernet AVB like" network protocol. Audio transport is according to IEEE1722 with 24-bit/48kHz resolution. Devices automatically detect each other on the network - identified by their names and their respective input channels. Out of all available network signals each myMix can select and mix up to 16 channels, which can be altered using in volume, tone control, panorama, solo and mute. For each channel there is also an effects send to the internal stereo effects unit to provide a true three-dimensional listening experience. The stereo mix signal is available as analog balanced line level and headphone output and can also be sent to the network. The mix signal can be used at a different location as a sub mix, for listening or as analog output from the network. All settings of the mixer, including input configuration and channel naming are automatically stored in one of up to 20 profiles to allow quick changes between different set ups.

myMix has a built-in recording and playback capability. With a single press of a button, the individual stereo mix and all selected individual network signals are recorded as multi-track time stamped 24-bit WAV files on optional SDHC cards. The individual files can be imported into recording software or played back and remixed in a myMix device. The "myMix Wave" software allows the playback of pre-produced multi-track material.

The audio quality, versatility and ease of use of the myMix system make it not only a recommendation for all personal monitoring mixing needs but allow for a wide range of applications from audio distribution, to control room listening and intercom functions, to music schools and other commercial sound and A/V applications.

myMix system audio signal flow diagram



Each myMix has two local inputs for microphone for line level sources. They are streamed to the network and can be selected by every other myMix. The mix signal output is available as analog line level and headphone output and also selectable to be send as a network signal. This stereo mix signal can be selected from other myMix devices and used like all other input signals.

The IEX16L allows adding 16 more signals to the network. The IEX16L has line level inputs, the IEX16L-A analogue line level and digital inputs (ADAT® format). The number of IEX as well as the number of audio channels is only limited by the switch capacity. The recommended switches can handle about 160 audio channels.

myMix System Network

In traduce in January 2010, myMix was one of the first products on the market using an “Ethernet AVB like” protocol. The audio transport is according to IEEE1722, while the overheads are proprietary for the use of conventional “off-the shelf” Fast Ethernet switches. Each myMix device is using a 100Mbps full duplex connection to the switch allowing for up to eight audio pairs (=two dual mono or one stereo signal) or 16 audio channels to be streamed in 24-bit, 48kHz with low latency (<1ms). Up to 16 audio channels on the network can be operated by simple unmanaged Fast Ethernet switches, larger systems need a managed Fast Ethernet switch that supports multicast filtering (IGMP snooping). The configuration files for the recommended models are available on www.myMixaudio.com/support.

The smallest system is the direct connection of two devices, two myMix or one myMix and one IEX16L



The typical system uses one switch to distribute the data.

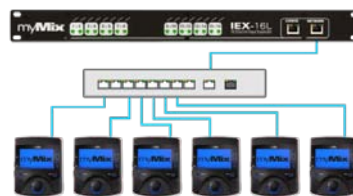

If two switches are needed all data is forwarded via the gigabit uplink ports.



More than two switches get connected to a central GB switch

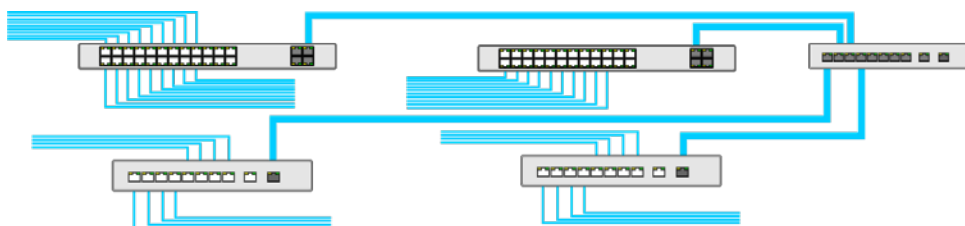

Name based operation – Channel editing -Mixing

To allow a fast and easy identification for the audio signals, and enable configuration changes by the press of a button, all audio channels in the network get named. Each myMix unit recalls the MAC address of the transmitting device as well as the channel name and stores the all parameters referring to that specific network channel.



Each channel that is selected for the mix can be edited by moving the with encoder button to the channel and press it. The first parameter that comes up is the volume control, as this is the most needed parameter. Other functions are available via the soft keys on the right side. These include a tone control β adding bass or treble to the signal, the stereo effects send for a 3D sound image, and panorama)or balance) for the positioning. Solo and Mute are available directly from the main screen.

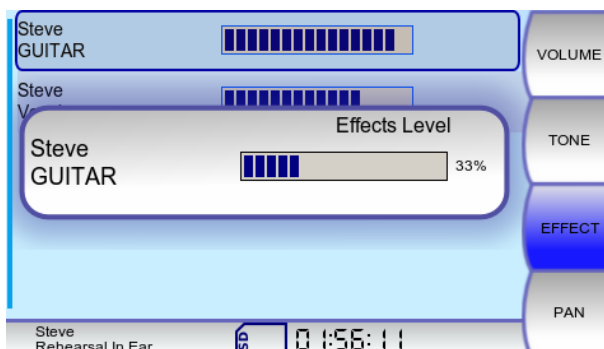
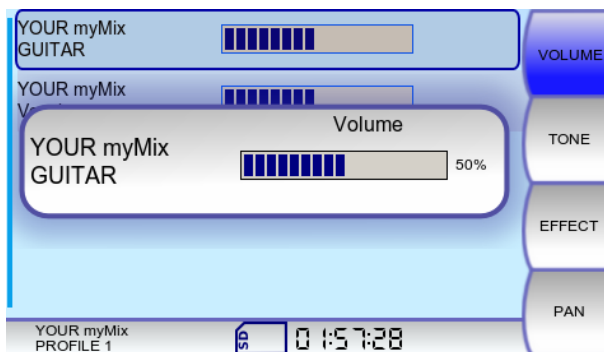

Built in stereo effects – the importance of a three-dimensional sound image

The stereo output of a myMix can be used with loudspeakers or headphones, but is absolutely ideal for the use with in-ear monitoring systems. The advantages of IEM for the overall production are huge, but there are still certain resentments from musicians, many times explained as “unreal, strange feeling, dead sound, no room, “. All signals we hear include information about their position, resulting from the time difference of a signal reaching our two ears. If a signal or monitor mix is being fed in mono, both ears receive the signal with the same time, which makes it impossible for the brain to position the signal- the mix is heard one dimensional. Being able to pan signals within a stereo image allows to make that a two dimensional experience. The built in stereo effects in myMix add “room information” to that image. It is not a feature to simply please musicians, but helps achieving a nearly natural, three dimensional listening experience when using IEMs. myMix has three room presets, three reverb presets and a adjustable delay.

Channel detection and selection

On the myMix network new audio channels are automatically detected. A new channel on the network could be a new device, or changing channel names on already existing devices. They got displayed automatically on the mix screen until the capacity limit of 8 pairs is reached.

The menu “Remote Channel Select” allows to select or deselect audio channels individually from the network. The selection of a channel (the MAC address of the sending device and the alphanumeric value of the channel name) is automatically stored in the current profile. Once a channel has been deselected it won’t show up on the mix screen any more.

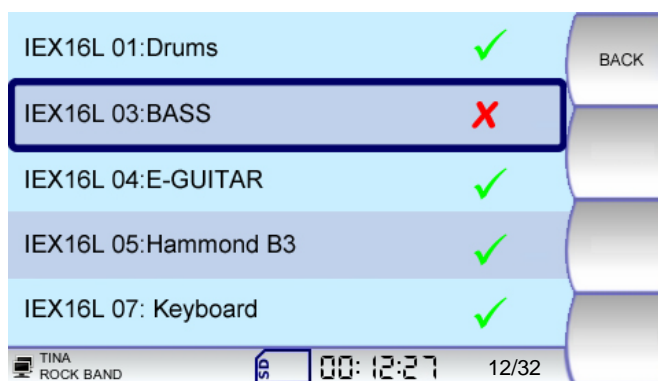

The channel counter on the right side of the control bar is showing the amount of selected channels and the amount of currently available audio channels on the network. Because of the audio streaming in pairs this indicator is only showing even figures.

Input Configuration of myMix

The two local inputs of a myMix accept a microphone level signal on the XLR and a line level signal on the balanced jack of the Neutrik® combo connector. Phantom can be activated. Input modes include dual mono, stereo, mono or none. If audio inputs are selected they can be named using 16 alphanumeric figures. These names combined with the MAC address are transparent throughout the network and used for the channel identification. This menu also allow to activate the stereo mix to

be sent to the network, so other devices can use it to listen to, either as submix, or as general content.

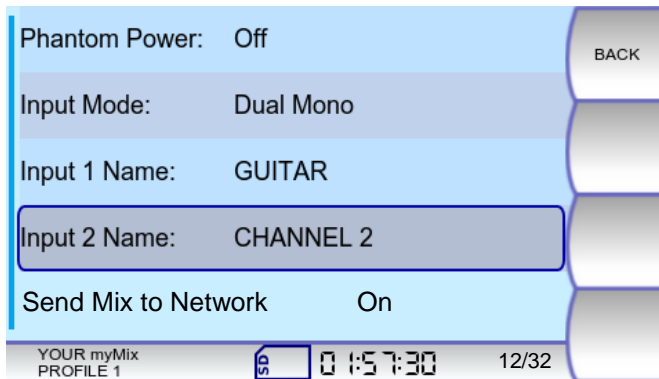

The IEX16L has 8 dual inputs for line level sources, which can be configured as dual mono or stereo channels and named like the channels on myMix. The IEX16L-A has additional digital, optical inputs in ADAT® format.

Profiles

The input configuration, including the channel naming, the remote channel selection, all parameters of the mixing page, including the selected effect type and stereo 4-band master eq are automatically stored in the current profile. myMix can store up to 20 profiles, which can be named and allow for fast changes between configurations. When a profile is created it starts as a copy of the last current profile, all changes from that point on will get stored. Because the profiles uses the complete channel name, changing the name of a channel of the same physical input makes it a new channel on the network, which will be stored with its own set of parameters. A profile can not only be used to recall different mix settings, but also to appear with different names on the network, that are selected and set differently. This can be used for example in a intercom/listening situation to talk to a dedicated group of people using one name for the talkback microphone channel and when switching profile and input channel name to talk to a second group.

A web browser based software to allow to up and download all profiles and preferences from myMix and IEX16 devices is currently under development and scheduled for June 2012.

Recording and Playback

myMix has the capability to record the stereo mix as well as the individual channels as time stamped 24-bit wav files on a SDHC card by the press of a single button. SDHC cards up to 32GB are supported, which allows for a total capacity of about 3 hours for 16 tracks. The recorded files are saved in a folder called session and can be directly imported to any computer audio production software. In addition, the multi track files can also be played back in a myMix and remixed. The play along mode allows to mix the local inputs with 14 tracks from the SD card. This is a very useful tool for musician or producers to work with material without any additional support. The free software

tool “myMix Wave” allows to use wav files from pre-produced multi-track material to be used for playback in myMix.

Send Mix to Network

A very useful feature for more demanding application is the possibility to send the stereo of a myMix to the network and use it like any other input signal in a mix. This allows the creation of submixes within the system, if somebody likes to control more than 16 audio channels, adding a second myMix increases that count to 30. If a myMix is used to playback audio material, this function allows others on the network to listen to the playback. Finally, engineers like the idea being able to listen to the mix of a musician by the press of a button.

myMix CONTROL

myMix Control is a web browser based application for remote configuration and editing of myMix systems. The myMix PLUG network interface exchanges the data between the myMix devices and the client computer and also acts as web server.

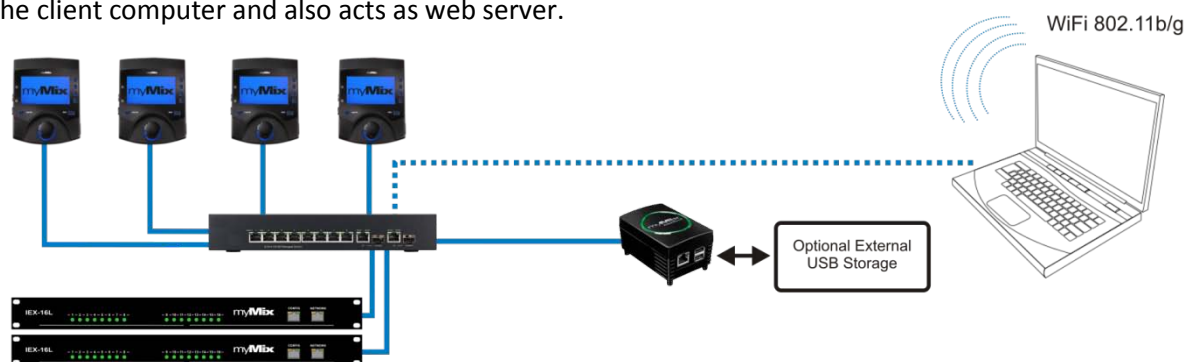

myMix CONTROL allows to up and download complete system settings (project file), as well as individual data from myMix and IEX. It is also possible to edit any myMix and IEX16 in it's parameters. In addition to the normal functions there are lock settings that allow to customize the access of a myMix user specific. The lock settings can also be saved and transferred to other devices. Detailed information about myMix CONTROL on www.mymixaudio.com/mymix-control

Firmware Updates- Future Proof

The myMix firmware is permanently under development. New features are added which can be brought to the device using an SD card for a firmware update. All processing in the myMix is done by a FPGA, so future changes, including modified network protocols (e.g. “final” Ethernet AVB) are all possible on that platform.

Some dedicated application examples

The following examples are a selection to demonstrate the wide range of applications and versatility of the myMix system. The fully decentralized concept combined with the used of conventional and non proprietary Ethernet infrastructure make easily scalable from one unit to hundreds. myMix doesn't require a special center or master unit and can be operated stand alone or integrated in a sound system. A variety of audio input connection options is shown in appendix A.

Application Band Rehearsal

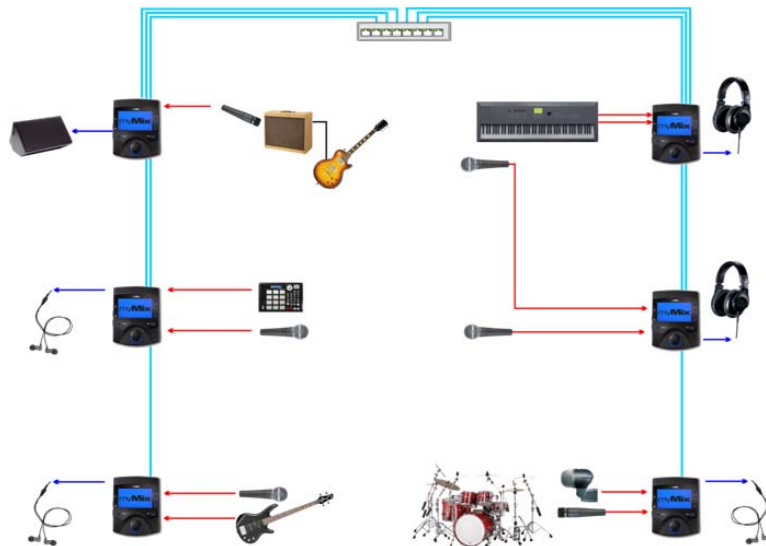

Audio sources are connected directly to the local inputs of myMix, without using a mixing console.

Application Live Band with main mixing console

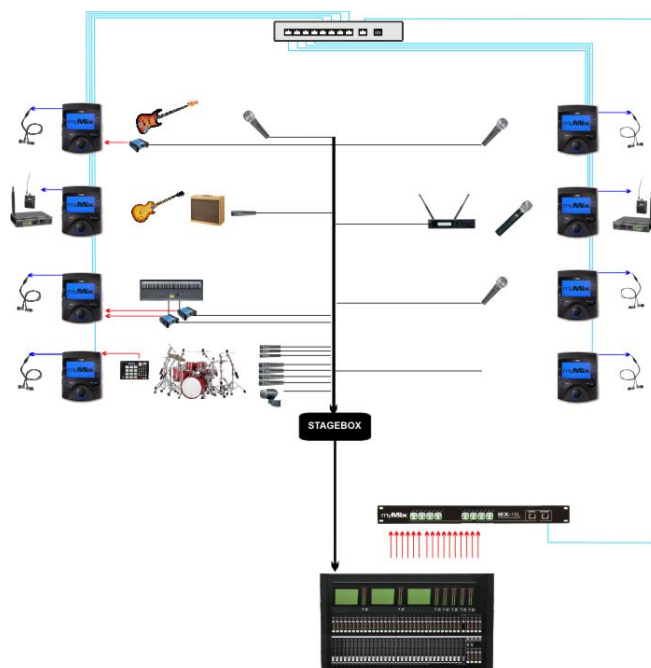

Submixes are fed from the console to an IEX16L(A), some direct inputs on stage are used in addition.

Application Big Band

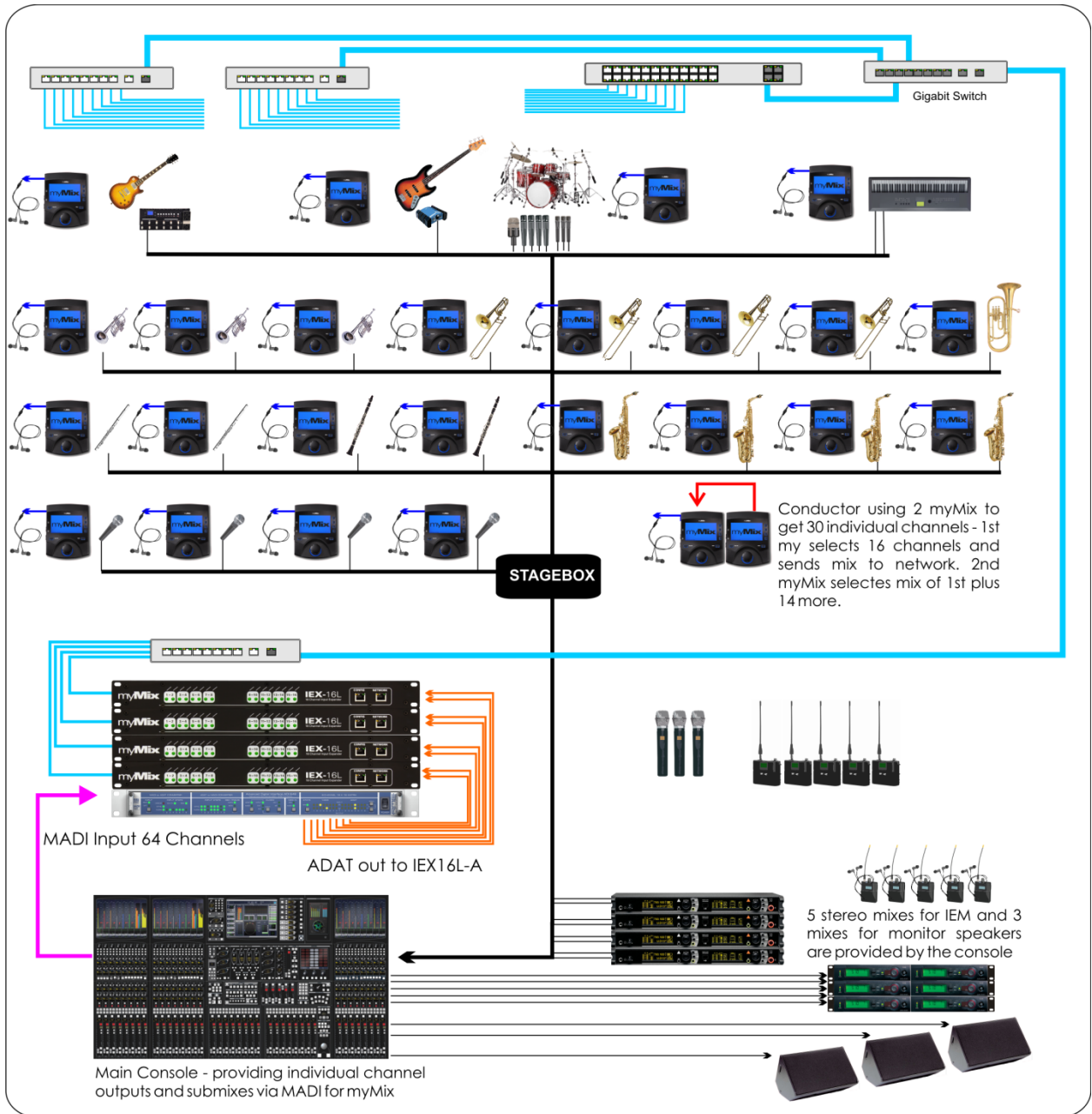

Large set up with dedicated monitor console. The monitor mixes for the solo artists are provided from the monitor console. Sub mixes and all individual instruments – up to 64 audio channels are send to the myMix system using a MADI signal via an RME ADI-648 interface to 4 IEX16L. The 64 channels in the network allows everybody in the band to select individual channels including the own instrument combined with some sub mixes.

Application Signal Distribution

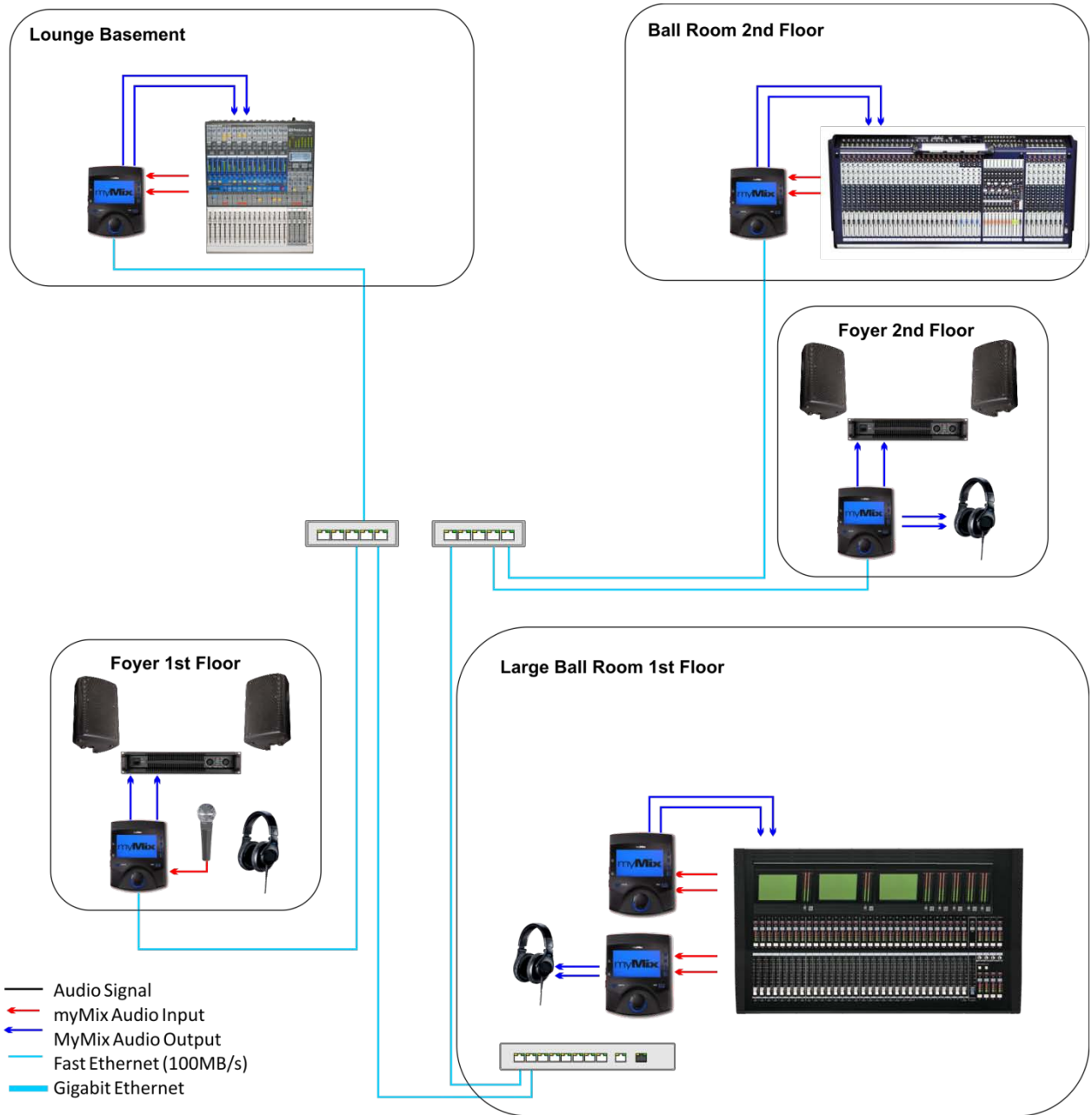

The easy CAT 5 connection allows to network signals from several stages easily for portable set ups. For longer cable runs a switch can be used as repeater.

Application Control Room Listening/Talkback

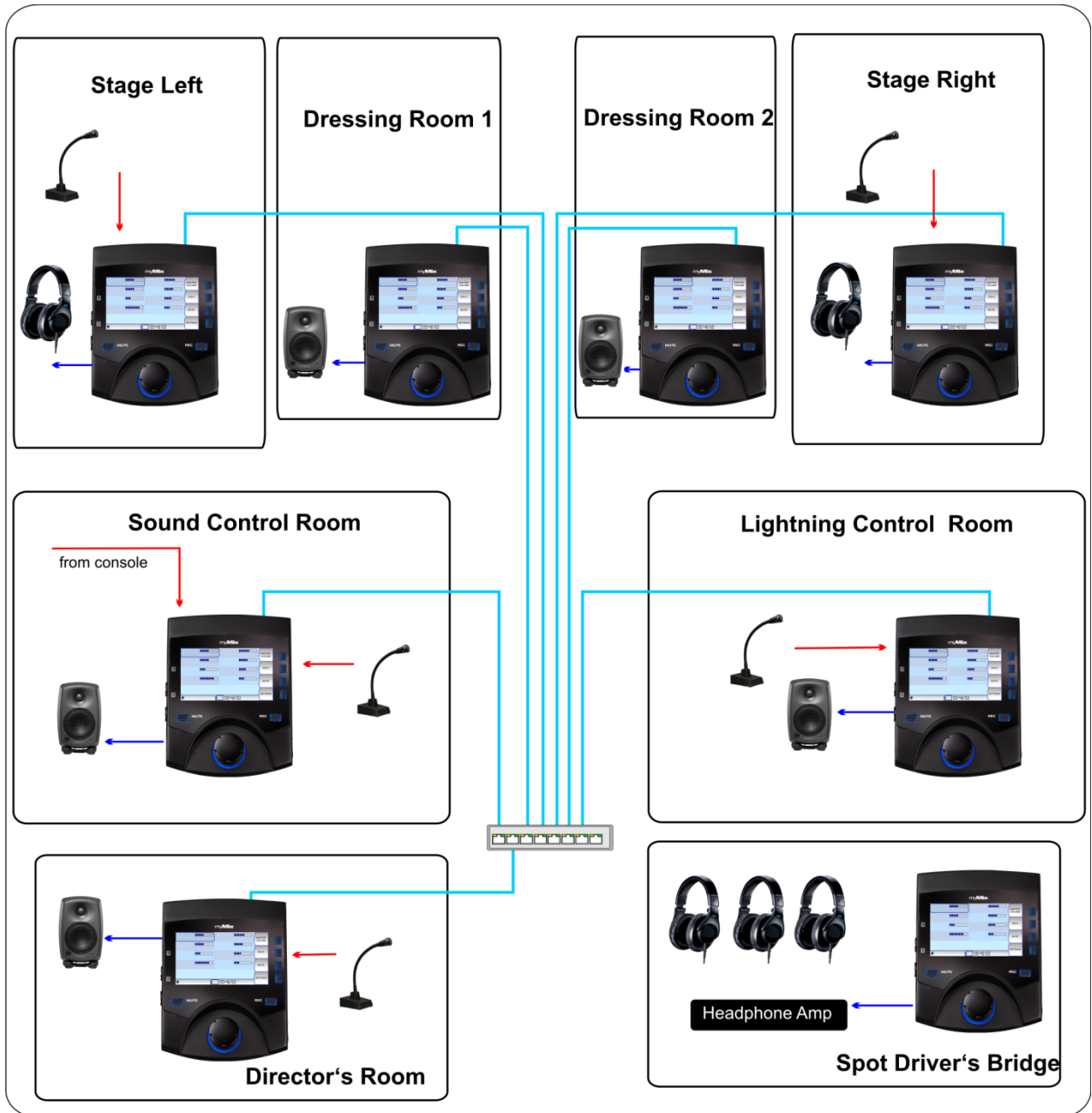

myMix system used for listening and talkback for the crew. Dedicated profiles can be used to talk to individual group of people, e.g. light crew, sound crew, all...

Application Large Live Production

In this set up myMix is not only used as monitoring system for the musicians, the crew is using myMix as listening and intercom system, while the RF operator uses 8ch from the IEX16 to monitor individual wireless channels. Four myMixes are used to transport the mix signal for users of wireless IEM to the transmitters via network.

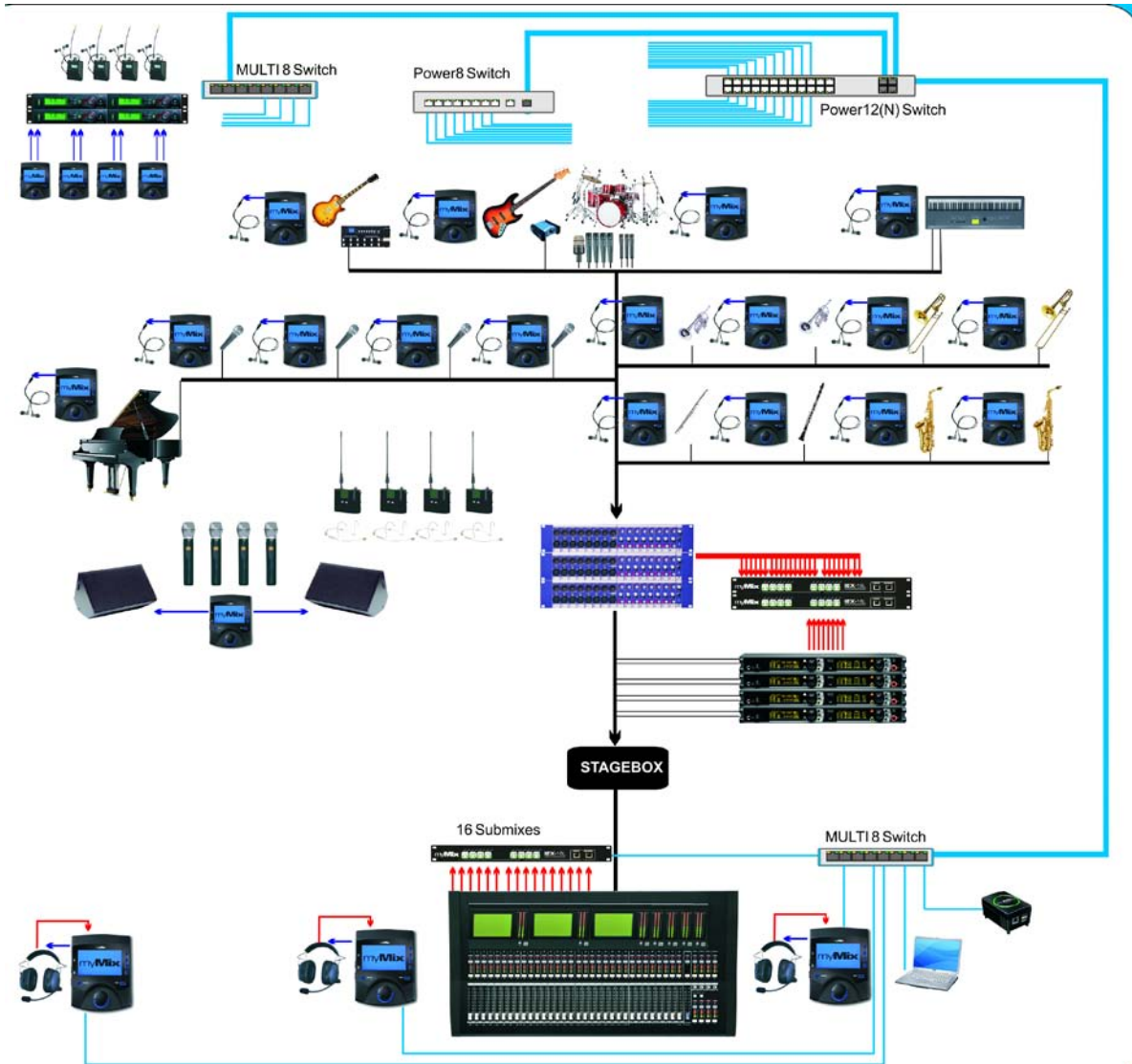

Application Music School

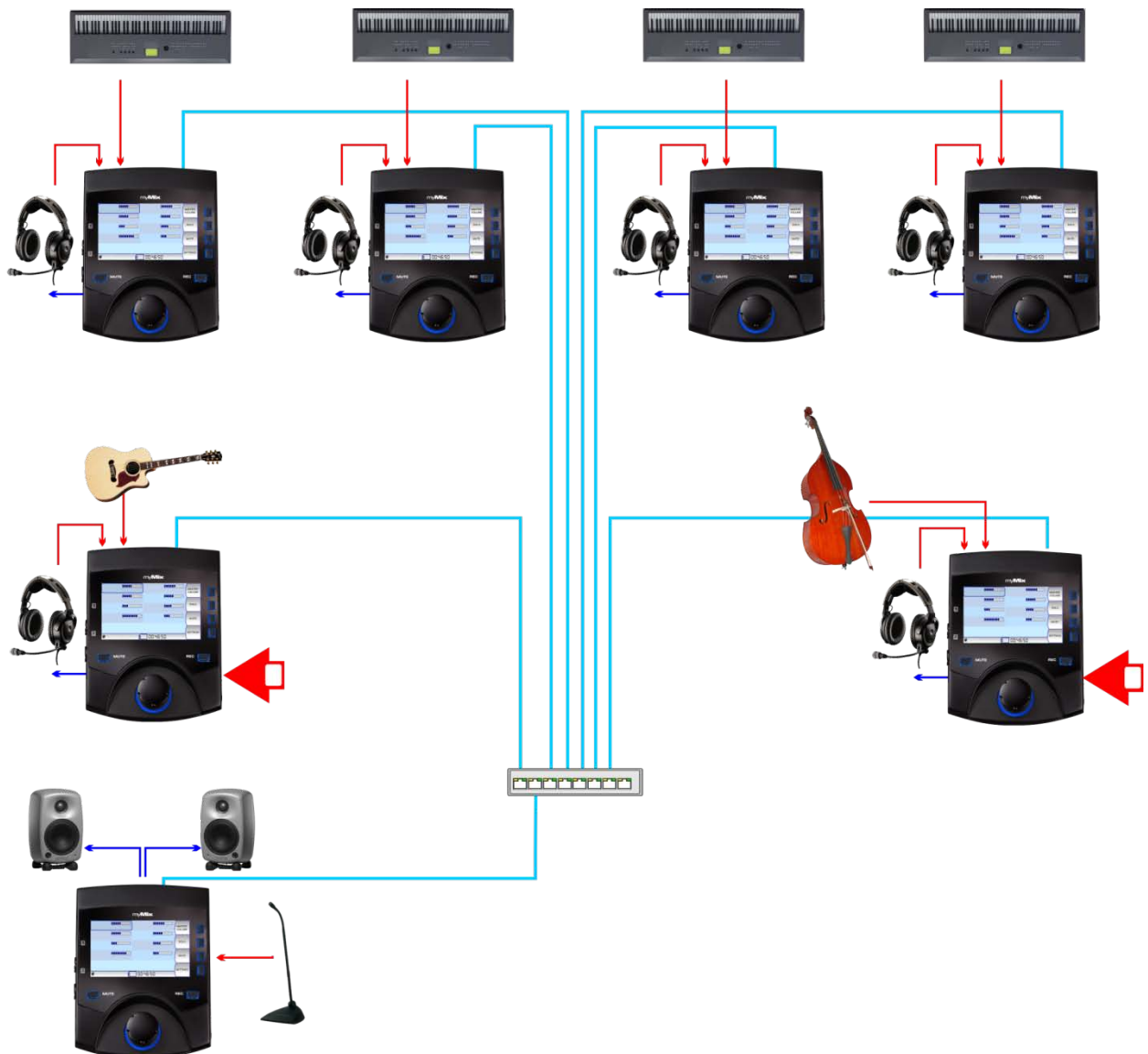

The teacher can listen and talk to individual students that play on their own, or play along to a multi track session from SD card using a dedicated profile for each student. The students connect the instrument and the talkback microphone to the local inputs. The teacher could also use the second input for an instrument.

Appendix A – myMix Connectivity

There is a wide variety of getting analogue as well as digital signals into the myMix system. The power of the myMix is that you can combine all of them at any time.

Splitting Microphone Signal for myMix and Main Console using a Y-Cable



Using the Multicore Return/Output Box for an Input from the Main Console to IEX-16L



Using the Multicore Return for an Input from the Main Console to myMix

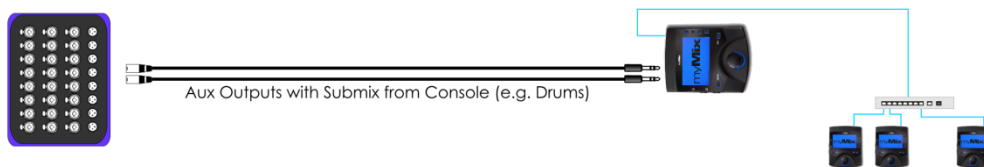

Splitting a Live Level Signal for myMix and Main Console using the DI Box

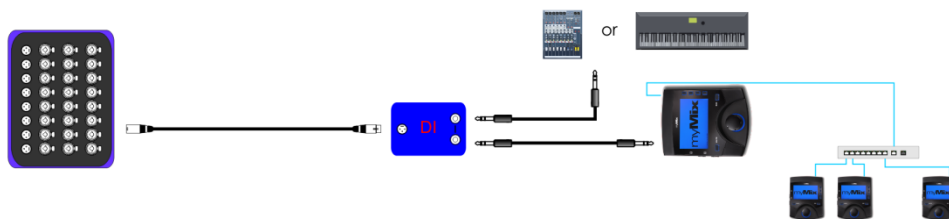

Using an Auxiliary Send from Main Console to IEX-16L

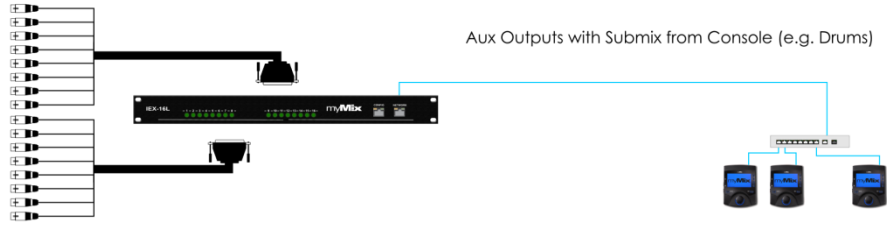

Using a Direct Out (Pre Fader) from Main Console to IEX-16L



Using the Insert as Direct Out from Main Console to IEX-16L

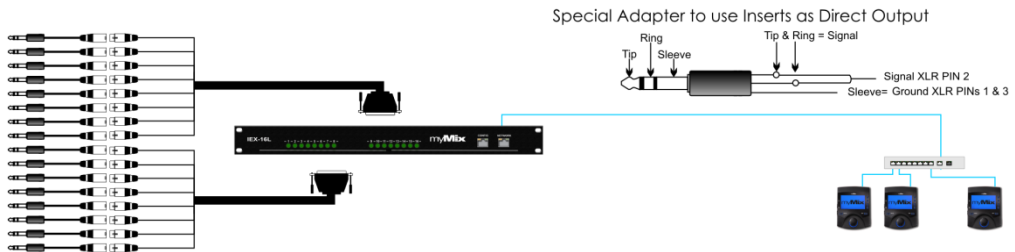

Splitting Microphone Signal using a central Microphone Split and IEX-16L with external Pre Amps

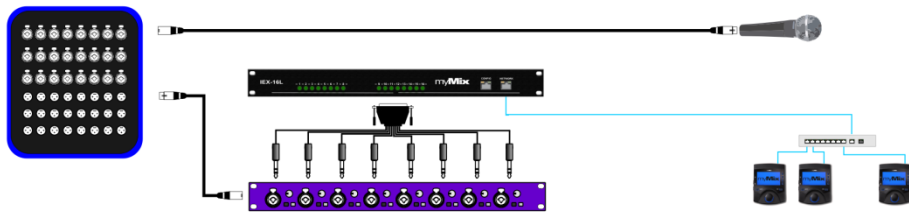

Splitting Microphone Signal for myMix and Main Console using a Combined Microphone Split/Pre Amp and IEX-16L

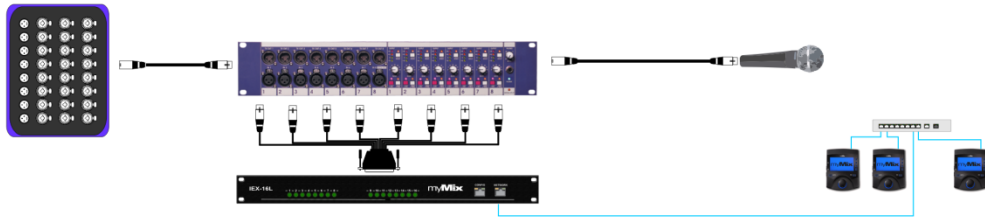

Using the ADAT Output from Main Console/Soundcard to IEX-16L(A)



MADI Signal Stream using a MADI to ADAT Interface and IEX-16L(A)

